

The Goring Kerr DSP IP Plus metal detector offers the most sensitive solution to meet your legal obligations and protect your brands. The design makes it ideally suited for harsh environments and incorporates the hygienic needs of the food industry by meeting and exceeding the IP69k requirements. The DSP IP Plus is the ideal QA solution to implement your HACCP plans.

## Goring Kerr DSP IP Plus Metal Detector

A high performance, cost-effective solution for harsh environments in the food and consumer industries



Thermo Electron Corporation provides advanced solutions for online and offline instrumentation. Thermo's Goring Kerr DSP IP Plus metal detector is an efficient and highly sensitive solution for process and end-of-line applications, primarily in food and consumer industries.

This metal detector is backed by a company with more than 50 years experience providing high quality metal detector systems. Goring Kerr was one of the world's first metal detector companies, established in 1948. Thermo Electron acquired Goring Kerr in 1999.

Goring Kerr was the first company to incorporate DSP (Digital Signal Processing) technology in metal detectors. This technology has been refined to ensure that the DSP IP Plus sets the industry standard for achievable detection sensitivity.

Increased sensitivity, without parallel improvements in stability, can cause wasteful, inefficient and false product rejection. Thermo recognizes this important factor by incorporating experienced mechanical design with special software techniques that provide this metal detector with both high sensitivity and high stability.

To meet the strict, modern hygiene standards of the food industry, the unit is constructed from stainless steel and has been certified to the IP69k standards. Every aspect of reliability has been taken into account in the design, including failsafe features.

AuditCheck™, a unique and patented device that validates the performance of the metal detector, is a standard feature of the Goring Kerr DSP IP Plus.

Your brand reputation depends on the quality of your product. Your bottom line depends on your efficiency. The Goring Kerr DSP IP Plus metal detector gives you more of both.

On the production line, time really is money, and when you package in a harsh environment with products such as meat, fish, cheese, sauces, preserves, etc., time spent washing up comes right off of your bottom line. But the DSP IP Plus withstands 1450 psi 80°C (176°F) high-pressure washdown without protection and has the IP69k certification to prove it. The DSP IP Plus is the only metal detector in the world with this exacting certification. No hand washing and no cover-up means more productivity and a better return on your investment.

The system's internal power supply saves space on your production line. It gives you more flexibility and simplifies installation. That means less hardware and external wiring to install and maintain, and one less set of connections to cause problems later.

Digital Signal Processing (DSP) delivers more accurate, less ambiguous detection. At maximum line speeds, the DSP IP Plus can detect metal that other systems might miss without rejecting product unnecessarily. Your operation stays fast and efficient, and waste is minimized without jeopardizing quality.

Our world-patented, AuditCheck, automatic performance verification system gives you even more control. By periodically monitoring the performance of the metal detector, it quickly detects and reports even small changes in sensitivity. This lets you fine-tune operations in real-time to deliver more product and waste less, while avoiding expensive quarantine and embarrassing recalls.

#### **Software Signal Enhancements**

Metal detection performance is not just a function of the head, but also the application conditions. Thermo has incorporated two new software enhancements designed to improve performance in specific applications.

In dry applications (where there is little or no product effect), a significant improvement can be achieved using the Phase Controlled Noise Reduction™ (PCNR) feature. PCNR reduces the background noise, thereby increasing the signal-to-noise ratio, resulting in improved performance.

In wet applications, the Quadrature Noise Reduction™ (QNR) will greatly reduce the effect of mechanical vibration in many applications such as sausage-stuffing machines and pipeline applications.

These performance improvements will increase the effectiveness of your QA system and further protect your brand.

#### **Auto Frequency Select (AFS)**

Modern packaging lines must be flexible to accommodate both metalized and non-metalized packaging material. For peak metal detector performance, each category of packaging material requires a different operating frequency.

With AFS, the metal detector can automatically change from one frequency to another when different products are selected from the library. This feature also enhances operational efficiency when products with widely different characteristics are packaged on the same line.

When AFS is in effect, other critical system parameters (such as amplifier gain) may also be selected to optimize the metal detector's performance. Performance optimization, by using AFS, will give you greater flexibility in line usage at the same time, reduce line operating costs.

#### **Total Quality Solution™ (TQS)**

Any metal detector is seen as a QA tool. Thermo has built features into the Goring Kerr DSP IP Plus metal detector that provide a unique Total Quality Solution (TQS). The Goring Kerr TQS will save line operating costs and increase efficiency due to improved QA with less operator intervention. TQS has a number of elements:

##### **Reject Validation**

High quality metal detection is only as good as the automatic reject mechanism. To ensure that the reject mechanism functions correctly, Thermo has introduced the reject validation option. The validation option monitors the reject pack and ensures that it travels into the reject bin. If it does not, then an alarm is generated. Reject validation also takes place during the Goring Kerr quality test, which gives an early warning of any reject mechanism problems.

#### **Goring Kerr Quality Test**

The Goring Kerr quality test is a mechanism that ensures manual tests are carried out at the prescribed times. The operator is prompted to pass test spheres through the head at the appropriate time. If these are correctly rejected, the test is considered to be satisfactory and an appropriate report is generated. If the test fails to be completed in an appropriate timescale, an alarm will be generated.

#### **AuditCheck**

##### **Automatic Performance Verification**

AuditCheck is a unique and world-patented device that automatically monitors the sensitivity performance of the metal detector. A test shuttle is pneumatically passed through the head and the resulting signal is compared to calibration data. The test is carried out on a regular, user-defined basis. Any deviation from standard is reported, and the operator can take appropriate remedial action. Small changes due to product effect can be identified early for re-calibration. These detected changes reduce cost by eliminating downtime and re-work.

Studies have shown that AuditCheck offers considerable savings as a result of reduced manual testing and reduction or elimination of product quarantine and re-work. The AuditCheck test results are reported and printed as required.

#### **Aftermarket Services**

A full range of aftermarket services is available to support the Goring Kerr DSP IP Plus metal detector throughout its lifetime, including commissioning and validation at the time of installation. A full range of operating and maintenance training modules are available either on site, or at one of the Thermo worldwide training facilities.

To ensure maximum operational efficiency, Thermo offers on-site maintenance contracts and a full, spare-parts service.

**Available Options**

- Remote Control Panel
- Local or Remote 80 column printer for printing reports from the AuditCheck automatic performance validation unit
- Menus available in English, Italian, Spanish, French, Dutch, German, Polish, Finnish, and Czech
- Reject Verification / Bin Full
- Certified Test Spheres
- DSPnet Network Software
- SCADA protocols:
  - Modbus RTU (RS485)
  - Modbus TCP/IP (Ethernet)
- Vertical Mount

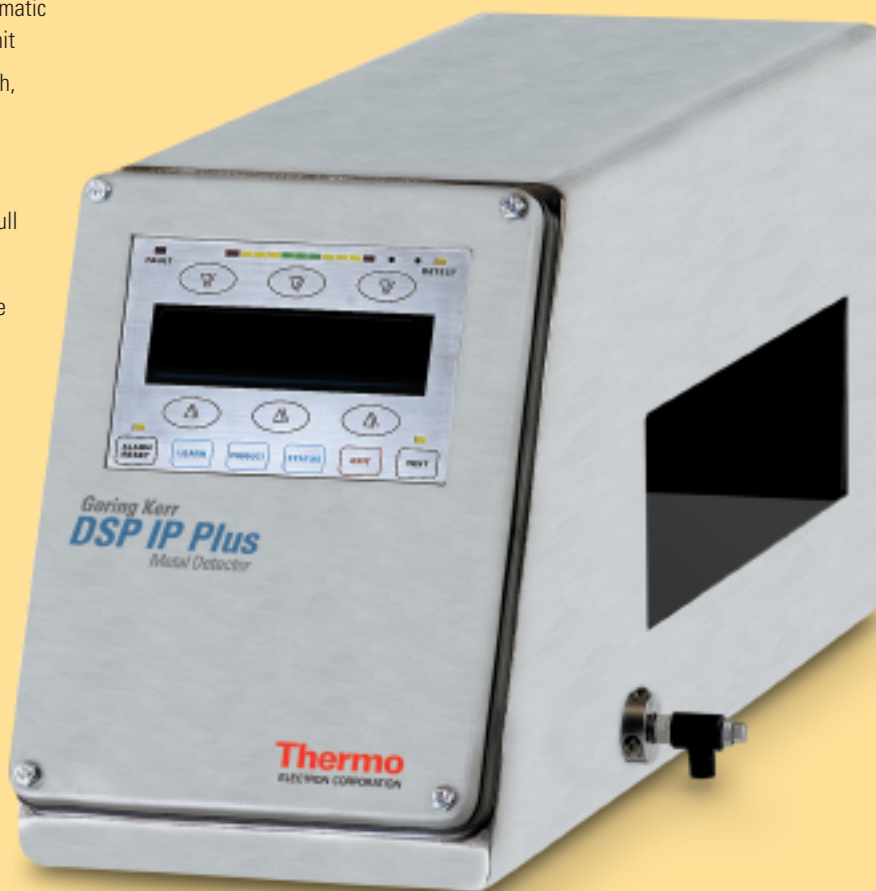
**Goring Kerr DSP IP Plus Metal Detector**

## Specification

**General Specifications**

Operating Temperature	-10°C to +40°C (+14°F to +104°F)
Relative Humidity	20% to 80% non-condensing
Electrical Supply	85 V to 260 VAC single phase plus earth; 47 Hz to 70 Hz; 35 watts maximum
Air Supply	5.5 bar (80 psi) for AuditCheck
Product Speed	1.0 m/min (3.1 ft/min) to 350 m/min (1000 ft/min); Dependent upon aperture size
Outputs	5 Relays; 250 V AC, 1 amp maximum; 50 V DC 1 amp maximum
Output Allocation	Reject; AuditCheck; Fault; Alarm; QA Lamp
Inputs	5 Optically Isolated; Active 12 V DC 2k input resistance with negative logic; +12 V auxiliary supply for input sensors
Input Allocation	EMU / Speed Sensor; Keylock; Product Select; Infeed PEC; Reject Confirmation 1 (bin full); Reject Confirmation 2; External Suppression
Serial Port (option)	Configurable: RS232 / RS485
Approvals	CE and cCSAus, IP69k
Manufacturing Quality	ISO9001 certified

Specifications

Goring Kerr DSP IP Plus Metal Detector — Physical Dimensions

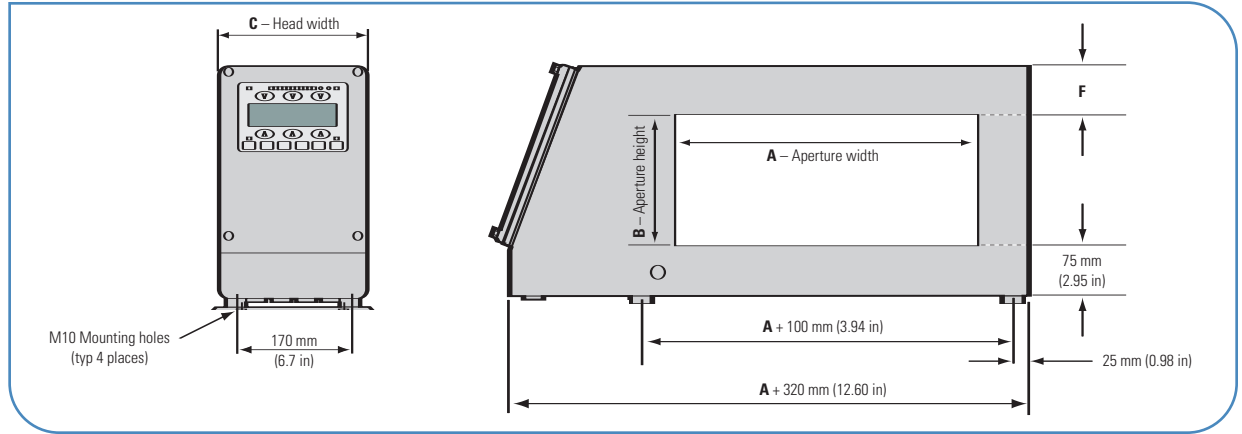

Goring Kerr DSP IP Plus Metal Detector — Standard Aperture Sizes (non-standard sizes available by special order)

		Aperture Height (B)															
		2 in 50 mm	3 in 75 mm	4 in 100 mm	5 in 125 mm	6 in 150 mm	7 in 175 mm	8 in 200 mm	10 in 250 mm	12 in 300 mm	14 in 350 mm	16 in 400 mm	18 in 450 mm	20 in 500 mm			
Aperture Width (A)	4 in 100 mm			C220 F125													
	5 in 125 mm			C220 F125	C220 F100												
	6 in 150 mm			C220 F125	C220 F100	C220 F075											
	7 in 175 mm			C220 F125	C220 F100	C220 F075	C220 F075										
	8 in 200 mm		C220 F150	C220 F125	C220 F100	C220 F075	C220 F075	C220 F075	C220 F075								
	10 in 250 mm	C220 F175	C220 F150	C220 F125	C220 F100	C220 F075	C220 F075	C220 F075	C220 F075	C220 F075							
	12 in 300 mm	C220 F175	C220 F150	C220 F125	C220 F100	C220 F075	C220 F075	C220 F075	C220 F075	C220 F075	C220 F075						
	14 in 350 mm	C220 F175	C220 F150	C220 F125	C220 F100	C220 F075	C220 F075	C220 F075	C220 F075	C220 F075	C250 F100	C250 F100					
	16 in 400 mm	C220 F175	C220 F150	C220 F125	C220 F100	C220 F075	C220 F075	C220 F075	C220 F075	C220 F075	C250 F100	C250 F100	C270 F100				
	18 in 450 mm	C220 F175	C220 F150	C220 F125	C220 F100	C220 F075	C220 F075	C220 F075	C220 F075	C220 F075	C250 F100	C250 F100	C270 F100	C270 F100	C270 F100		
	20 in 500 mm	C220 F175	C220 F150	C220 F125	C220 F100	C220 F075	C220 F075	C220 F075	C220 F075	C250 F100	C250 F100	C270 F100	C270 F100	C270 F100	C270 F100	C320 F130	
	22 in 550 mm	C220 F175	C220 F150	C220 F125	C220 F100	C220 F075	C220 F075	C220 F075	C220 F075	C250 F100	C250 F100	C270 F100	C270 F100	C270 F100	C320 F130	C320 F130	
	24 in 600 mm	C220 F175	C220 F150	C220 F125	C220 F100	C220 F075	C220 F075	C220 F075	C220 F075	C250 F100	C250 F100	C270 F100	C270 F100	C320 F130	C320 F130	C320 F130	
	26 in 650 mm	C220 F175	C220 F150	C220 F125	C220 F100	C220 F075	C220 F075	C220 F075	C220 F075	C250 F100	C270 F100	C270 F100	C320 F130	C320 F130	C320 F130	C320 F130	
	28 in 700 mm	C220 F175	C220 F150	C220 F125	C220 F100	C220 F075	C220 F075	C220 F075	C250 F100	C250 F100	C270 F100	C320 F130	C320 F130	C320 F130	C320 F130	C320 F130	
	30 in 750 mm	C220 F175	C220 F150	C220 F125	C220 F100	C220 F075	C220 F075	C220 F075	C250 F100	C250 F100	C270 F100	C320 F130	C320 F130	C320 F130	C320 F130	C320 F130	
32 in 800 mm	C220 F175	C220 F150	C220 F125	C220 F100	C220 F075	C220 F075	C250 F100	C250 F100	C270 F100	C320 F130	C320 F130	C320 F130	C320 F130				
34 in 850 mm	C220 F175	C220 F150	C220 F125	C220 F100	C220 F075	C220 F075	C250 F100	C270 F100	C270 F100	C320 F130	C320 F130	C320 F130	C320 F130				
36 in 900 mm	C220 F175	C220 F150	C220 F125	C220 F100	C220 F075	C250 F100	C250 F100	C270 F100	C320 F130	C320 F130	C320 F130	C320 F130	C320 F130				
38 in 950 mm	C220 F175	C220 F150	C220 F125	C220 F100	C220 F075	C250 F100	C250 F100	C270 F100	C320 F130	C320 F130	C320 F130	C320 F130					
40 in 1000 mm	C220 F175	C220 F150	C220 F125	C220 F100	C220 F075	C250 F100	C270 F100	C270 F100	C320 F130	C320 F130	C320 F130	C320 F130					
44 in 1100 mm	C250 F175	C250 F150	C250 F125	C250 F100	C250 F100	C250 F100	C270 F100	C270 F100	C320 F130	C320 F130	C320 F130						
48 in 1200 mm	C250 F175	C250 F150	C250 F125	C250 F100	C250 F100	C250 F100	C270 F100	C270 F100	C320 F130	C320 F130							
52 in 1300 mm	C250 F175	C250 F150	C270 F125	C270 F100	C270 F100	C270 F100	C270 F100	C270 F100	C320 F130	C320 F130							

Legend

Variable head width C in millimeters → C220 F075 ← Variable height measurement F in millimeters

For full mechanical installation information, please contact your local sales office.

©2005 Thermo Electron Corporation. All rights reserved. AuditCheck, Phase Controlled Noise Reduction, Quadrature Noise Reduction and Total Quality Solution are trademarks of Thermo Electron Corporation. Specifications, terms and pricing are subject to change. Not all products are available in all countries. Please consult your local sales representatives for details. Literature Code PI.0031.0405

- |   |  |  |  |
|---|--|--|--|
| Argentina<br>+54 (0) 11 4 334 3827<br>+54 (0) 11 4 334 9159 fax | France<br>+33 (0) 1 60 92 48 00<br>+33 (0) 1 60 92 49 00 fax | Mexico<br>+52 (01) 55 5638 0237<br>+52 (01) 55 5639 2227 fax   | United Kingdom<br>+44 (0) 1788-820300<br>+44 (0) 1788-820301 fax |
| Australia<br>+61 (0) 8 8150-5300<br>+61 (0) 8 8234-5882 fax     | Germany<br>+49 (0) 208-824930<br>+49 (0) 208-852310 fax      | Netherlands<br>+31 (0) 33-454-9000<br>+31 (0) 33-454-9009 fax  | United States<br>+1 (800) 227-8891<br>+1 (763) 783-2525 fax      |
| Canada<br>+1 (905) 888-8808<br>+1 (905) 888-8828 fax            | India<br>+91 (0) 20-4011245<br>+91 (0) 20-26125739 fax       | Poland<br>+48 (0) 22848 3708<br>+48 (0) 22848 3708 fax         |  |
| Chile<br>+56 (0) 2-335-3388<br>+56 (0) 2-335-1590 fax           | Italy<br>+39 0521 78861<br>+39 0521 272914 fax               | South Africa<br>+27 (0) 11-609-3101<br>+27 (0) 11-609-3110 fax |  |
| China<br>+86 (0) 21 5465 7588<br>+86 (0) 21 6445 7830 fax       | Malaysia<br>+60 (0) 3 2300 1626<br>+60 (0) 3 2300 1636 fax   | Spain<br>+34 91-484-5954<br>+34 91-661-5572 fax                |  |