

The Thermo Scientific EZx contaminant detection system provides complete protection from metal, glass, stone, plastic and other dense foreign objects at a very affordable price. Especially attractive on lines utilizing new metallized film or foil packaging, the system is typically installed immediately after fill and seal. The EZx can screen your production 100% and immediately identify contaminants so you can take fast corrective action.

Thermo Scientific EZx™ Contaminant Detection System



Features and Benefits

- Designed to offer the lowest total cost of ownership of any X-ray system
- Unique source and detector design eliminates blind spots
- Certified for harsh environments, IP65 washdown
- Multiple size apertures available for optimum price/performance
- Intuitive on screen inspection results and run-time monitoring/adjustment
- QuickLearn Wizard gets you running in minutes
- New integrated rejecters, networking software and cooling options

The Thermo Scientific EZx contaminant detection system provides the optimum solution for locating foreign objects commonly found in packaged food production environments. Utilizing an innovative X-ray generation and processing approach (patent applied for), the system can find virtually any substance that is denser or sharper than the object it is contained in. This defect coverage is far superior to traditional magnetic metal detectors and can help overcome many of the traditional product effect challenges of those devices.

Designed with production line users in mind, the EZx is very easy to learn and use. The built-in QuickLearn Wizard enables you to set up a new product in minutes. It automatically selects how to generate and

process an image of your product. And once running, the display shows an intuitive red light/green light status monitor along with simple summary statistics and reject images.

Unlike other X-ray systems, the EZx platform was engineered to help you make the transition from metal detectors simple. It is available in five aperture sizes and various line heights; comes as a standalone system or with integrated rejecters; operates over a wide temperature range; meets IP65 washdown requirements; and adheres to even the strictest X-ray radiation standards. Although EZx is extremely reliable, in the event of a problem its modular design minimizes the time to repair. It can even be networked enabling simple and quick storage of all data for traceability.



EZx system with optional integrated rejecter (air blast, lockable bin and reject verify/bin full photo eye shown)



Transfer data to any PC via the built-in USB port or optional network connection



QuickLearn Wizard

Learning a new product is accomplished in minutes with the EZx touchscreen and a built-in wizard that makes all the tough decisions a snap. All you do is show the system several packages and it automatically determines what is “good.” Then you are prompted to test your setup by passing contaminants through the aperture—just like you would do during periodic audits when online. “Bad” packages are flagged and a zoomable image displays what the system found. Of course, all machine parameters can be set manually and new contaminant finding algorithms are available periodically as software upgrades.

Unique X-Ray Design

The Thermo Scientific EZx is a conveyerized X-ray system designed to look and work more like a metal detector than a complex X-ray system. It utilizes a unique wrap around detector that assures there are never any “blind spots” in the inspection tunnel. The exceptionally reliable, wide beam X-ray source can easily penetrate most packaged foods without any trouble.

Intuitive Inspection Results

Summary inspection statistics are shown on screen and rejected product images can be reviewed when needed to determine corrective action. The run-time statistics data is logged by shift or batch for up to a month on the system. All statistics, images and log files can easily be transferred to a PC for archive and further analysis via a built-in USB port or optional Ethernet/FTP network connection.

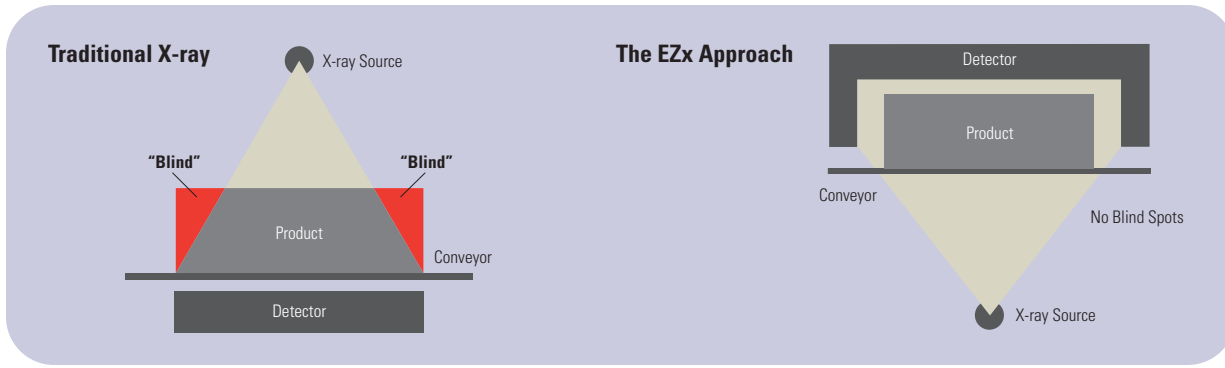

Innovative Machine Design

The EZx contaminant detection system was designed with food safety and sanitation principles in mind and has been tested to be IP65 compliant. All major components are modular for easy service from the front and the belt can be changed without tools. Five different conveyor heights are available and each is adjustable ± 50 mm (± 1.96 in) in the field. Several types of built-in reject mechanisms are available and general purpose I/O is included for external rejecters and custom applications. A photo sensor is included to trigger inspection and additional photo sensors are available to verify both product rejection and reject bin full. The system can operate in an environment up to $+40^{\circ}\text{C}$ ($+104^{\circ}\text{F}$) because of its built-in, extremely reliable vortex cooling. A cabinet air conditioning option is also offered for those installations where clean, dry compressed air is not readily available.

Optimized for Performance

Like traditional metal detectors, five aperture sizes are available (see Table 1) so you can optimize price and sensitivity to your package size. The X-ray source scans the aperture at a high rate resulting in typical inspection rates of 400 packages/minute or more. X-Ray detector calibration is automatically performed when loading and running a product and the detector is thermally stable so hot or frozen products do not affect performance. Finally, if inspection parameters need to be adjusted at run-time a password protected function is available to the technician. It displays the most recent conditions and enables changes on-the-fly with no impact to production.

Application Analysis and Aftermarket Services

Prior to purchasing an EZx contaminant detection system, our engineers will quickly and completely evaluate your application. A professional report is generated for review with your field salesperson. In addition, full machine specific characteristics are reviewed prior to order, assuring the system delivered meets your exacting requirements. After purchase, a wide range of services is available to support the EZx throughout its lifetime including full installation, training and radiation testing at the time of delivery. To ensure maximum operational efficiency, we offer on-site maintenance contracts and a full, spare-parts service. Finally, a Product Inspection Service (PIS) is available in many regions around the world to screen quarantined product, reducing costly scrap.

Available Accessories/Options

- Integrated reject systems including several rejecter types, reject verify and bill full photo eyes and lockable reject bins. This option is now available for all EZx models.
- Networking and expanded product storage. Includes Ethernet/FTP hardware and software and additional memory. Networking setup and training included with installation.
- Air conditioning cooling (replaces the standard vortex cooler)
- Additional certified metal (ferrous, non-ferrous, stainless steel) and soda lime glass test cards. A basic kit of cards is included standard with every system.
- Spare parts kits and basic parts including spare belts and conveyor bearings
- Product alignment rails
- Special photoeye sensors for triggering and reject verification of low profile, light weight packages
- Country/region specific radiation testing and certification
- Radiation survey meter

Easily view run-time parameters and adjust them on-the-fly for optimum performance

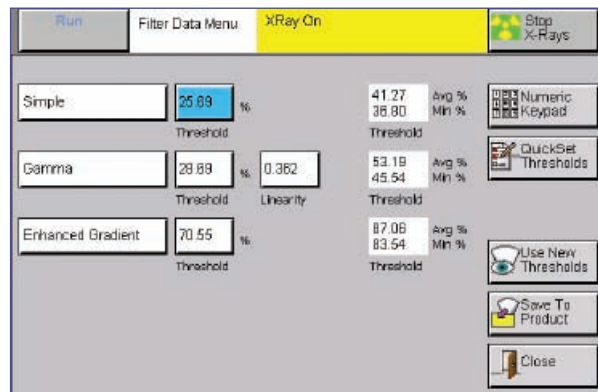

Table 1: EZx Application Parameters

EZx Model Number	Package Width	Package Height	Aperture Width	Aperture Height	Maximum Conveyor Speed
210	150 mm (5.90 in)	85 mm (3.3 in)	200 mm (7.90 in)	100 mm (4.0 in)	100 m/min (328 ft/min)
405	340 mm (13.4 in)	35 mm (1.4 in)	400 mm (15.8 in)	50 mm (2.0 in)	100 m/min (328 ft/min)
410	340 mm (13.4 in)	85 mm (3.3 in)	400 mm (15.8 in)	100 mm (4.0 in)	100 m/min (328 ft/min)
420	340 mm (13.4 in)	185 mm (7.3 in)	400 mm (15.8 in)	200 mm (7.9 in)	100 m/min (328 ft/min)
510	440 mm (17.3 in)	85 mm (3.3 in)	500 mm (19.7 in)	100 mm (4.0 in)	50 m/min (164 ft/min)
520	440 mm (17.3 in)	185 mm (7.3 in)	500 mm (19.7 in)	200 mm (7.9 in)	50 m/min (164 ft/min)

Thermo Scientific EZx

Application and X-ray Specifications

X-ray Power	160 Watts, 80 KV/2 ma maximum
Scan Rate	Up to 2000 lines per second
A/D Converter	12 bit, 4096 gray scale images
Warm-up Time	Less than 30 minutes
Typical Sensitivity	1-2 mm diameter for metal, >2 mm for other dense contaminants such as glass, stone and some types of plastic
Detection Filters Available	Simple threshold, gradient and enhanced (log contrast adjustment) gradient and Gamma correction
Other Image Processing Functions	Side and leading/trailing edge masking
Aperture/Product Width and Height	See specifics in Table 1
Maximum Belt Speed	See specifics in Table 1, depends on aperture width
Conveyor Heights (specify at order time)	750 mm (29.5 in), 850 mm (33.5 in), 950 mm (37.4 in), 1050 mm (41.3 in), 1150 mm (45.3 in); Field adjustable ±50 mm/±2 in
Conveyor Length	1.6 m (5.25 ft); does not include optional rejecters for models 410, 420, 510 and 520
Belt Material	USDA/FDA approved urethane
Inspection Trigger Photo Sensor	Through beam or optional range sensor for flat packages; 35 mm (1.4 in) minimum product gap required
Security/Safety Features	X-ray power key, four level password system, emergency X-ray/conveyor stop button, lead curtains, failsafe X-ray eminent and on indication light
Human Machine Interface (HMI)	Microsoft® Windows® CE touchscreen, 203 mm (8 in) diagonal
Language Interfaces Available	English, Spanish, French, Italian, German, Chinese and Czechoslovakian
Inspection Data Available	Packs inspected, accepted and rejected by shift and batch; Rejects timestamped and assigned a reject code
Data File Export	Via built-in USB port or optional network connection; Files tab/space/return delimited text for import to Microsoft Excel®
Built-in Rejecter Option	Air blast or pusher, lockable reject bin and reject verify/bin full photo eyes

Environmental, Electrical and Operational Specifications

Operating Temperature	+15°C to +40°C (+60°F to +104°F)
Relative Humidity	20% to 90%
Electrical Supply	85 VAC to 250 VAC, 50/60 Hz, autosensing, single phase
Digital Outputs/Allocation	Eight outputs, form C (SPDT) relays, 250 VAC 2A provided, assignable function
Digital Inputs/Allocation	Eight inputs, contact closure, 6 NPN, 2 NPN/PNP, 10-30 VDC 10 mA, assignable function
USB Port	Watertight USB 1.1; memory stick included
Network Option	10/100 Ethernet TCP/IP and FTP, RJ45 network connection
Compressed Air	Dry 80-100 PSI (5.5-6.9 bar), 40 CFM (1135 LPM), 25 micron air filter, 6.35 mm (0.25 in) tubing, NPT 0.25-in thread.
Machine Weight	227 kg (500 lb) not including rejecters

Conformance Tests and Certifications

Radiation Safety Conformance	FDA CFR 21 part 1020.40; UK IRR 1999; France NFC 74100; Canada RED Act; Spain CSNE (contact factory for other regional certifications)
Export/Safety Certification	CE, cCSAus, CSA
IP Washdown Conformance	IP65, see factory for test results; Full stainless steel type 304 construction
Ambient Noise at HMI	<75 dB (Meets OSHA 29 CFR 1910.95)
Emissions and Immunity	EN61326-1: 1997
Manufacturing Quality	ISO9001 certified facility

EZx Contaminant Detection System

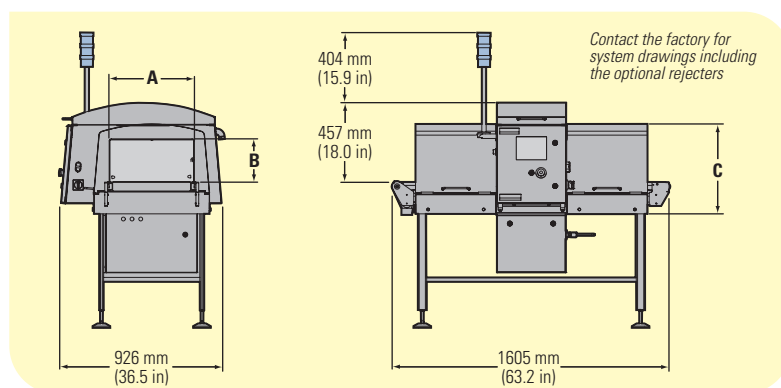

EZx Model Number	Dimension A	Dimension B	Dimension C
210	197 mm (7.76 in)	88.8 mm (3.50 in)	369.9 mm (14.56 in)
405	380 mm (14.96 in)	37.4 mm (1.47 in)	515.7 mm (20.30 in)
410	380 mm (14.96 in)	88.8 mm (3.50 in)	515.7 mm (20.30 in)
420	380 mm (14.96 in)	193.0 mm (7.60 in)	515.7 mm (20.30 in)
510	483 mm (19.02 in)	88.8 mm (3.50 in)	515.7 mm (20.30 in)
520	483 mm (19.02 in)	193.0 mm (7.60 in)	515.7 mm (20.30 in)

©2007 Thermo Fisher Scientific Inc. All rights reserved. Microsoft, Windows and Excel are either registered trademarks or trademarks of Microsoft Corporation in the United States and/or other countries. All other trademarks are the property of Thermo Fisher Scientific Inc. and its subsidiaries. Results may vary under different operating conditions. Specifications, terms and pricing are subject to change. Not all products are available in all countries. Please consult your local sales representatives for details. Literature Code PI.0037.0707

Argentina +54 (0) 11 4334 3827 +54 (0) 11 4334 9159 fax	France +33 (0) 160 92 48 00 +33 (0) 160 92 49 00 fax	Mexico +52 (01) 55 5638 0237 +52 (01) 55 5639 2227 fax	United Kingdom +44 (0) 1788-820300 +44 (0) 1788-820301 fax
Australia +61 (0) 8 8150-5300 +61 (0) 8 8234-5882 fax	Germany +49 (0) 208-824930 +49 (0) 208-852310 fax	Netherlands +31 (0) 76-579-5555 +31 (0) 76-571-4958 fax	United States +1 (800) 227-8891 +1 (763) 783-2525 fax +1 (763) 783-2500 direct
Canada +1 (905) 888-8808 +1 (905) 888-8828 fax	India +91 (20) 6626 7000 +91 (20) 6626 7001 fax	Poland +48 (0) 22 651 75 30 +48 (0) 22 651 75 35 fax	
Chile +56 (0) 2-335-3388 +56 (0) 2-335-1590 fax	Italy +39 05 217886-1 +39 05 212729-14 fax	South Africa +27 (0) 11-609-3101 +27 (0) 11-609-3110 fax	
China +86 (0) 21 6865 4588 +86 (0) 21 6445 1101 fax	Malaysia +60 (0) 3 5122 8888 +60 (0) 3 5121 8899 fax	Spain +34 91-484-5954 +34 91-661-5572 fax	